

The 422 proportional I/P Converter uses advanced electronic control to achieve outstanding performance.

It offers Fail Freeze operation in addition to conventional I/P characteristics and its rugged construction, minimum vibration effect and total weatherproofing makes it ideal for field application.

- *Advanced electronic control*
- *Fail freeze operation (output pressure retained on signal failure)*
- *Minimum Vibration Effects*
- *IP65 environmental protection*
- *ATEX Certified units available*

TYPICAL APPLICATIONS

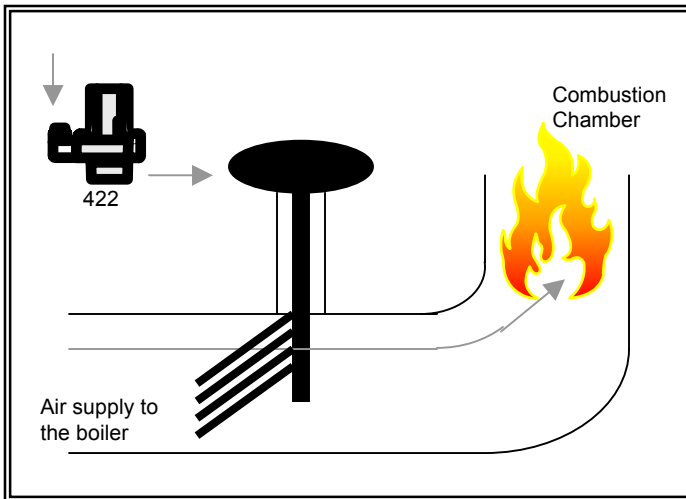

Solution:

The Type 422's unique characteristic of freezing the output pressure when power to the unit fails, in an I/P, is an essential feature in maintaining safety critical aspects of the temperature chamber. 4-20mA control signal and reaching output pressures up to 8bar (120psig), the 422 is compact, closed loop and therefore offers a high level of accuracy output.

If there is a power failure, failfreeze is important as large costs would be incurred for the re-purging of pipelines.

The damper valves are used to maintain a level of temperature in combustion of the water in creating steam and therefore power and failure of this could be catastrophic.

The 422 is an individual effective method of maintaining the integrity of the damper valve



Industry:

Any industry incorporating damper valves, particularly used in thermal power stations and gas transmission systems.



TECHNICAL DATA

Pneumatic

- Output Pressure 0.2 to 1bar (3 to 15psi) standard low pressure unit
0.2 to 8bar (3 to 120psi) standard high pressure unit
See Ordering Options
- Air Supply Oil free, dry air, filtered to 5 microns; at least 0.7bar above maximum required output pressure
- Flow Capacity Up to 300nL/min (10scfm)
- Air Consumption 0.2 l/min typical (0.007scfm) low pressure; 0.4 l/min typical (0.013scfm) high pressure
- Linearity Maximum <0.5 of span
- Hysteresis Maximum <0.1% of span
- Response Time 6 seconds (low pressure unit)/ 12 seconds (high pressure unit) (from 10 to 90% of output pressure into a 2 litre load)
- Temperature Sensitivity Typically <± 1% span between -10°C and +60°C
- Supply Sensitivity Negligible effect
- Port Sizes 1/4" NPT female standard (plus two integral 1/4" NPT gauge ports);

Other options available on request

Physical

- Operating Temperature -20°C to +70°C
- I.P. Rating IP65
- Electromagnetic Compatibility Compliant and CE marked in accordance with the EC Directive 89/336/EEC
Tested to standards: BS EN50082-2: 1995,
BS EN50081-2: 1994
- Material of Construction Zinc diecasting passivated and epoxy painted, Vertron glass/nylon cover; Nitrile diaphragms
- Weight 800g
- Mounting Position Operation in any orientation is possible without recalibration; integral surface mounting bracket provided for vertical mounting
- Vibration Effect Negligible effect for vibration level up to 3g, 5-500Hz

Electrical

- Input Signal 4-20mA (two wire); load presents 6 volts (±0.5V) constant voltage drop to the current source at 20mA
- Failure Mode Output pressure held at previous value when input signal fails; drift rate 0.02% in 30 seconds
- Connections 30mm square connector DIN 43650 provided, mountable in four directions
- Span/Zero Adjustable 20% output range

INSTALLATION DIAGRAM

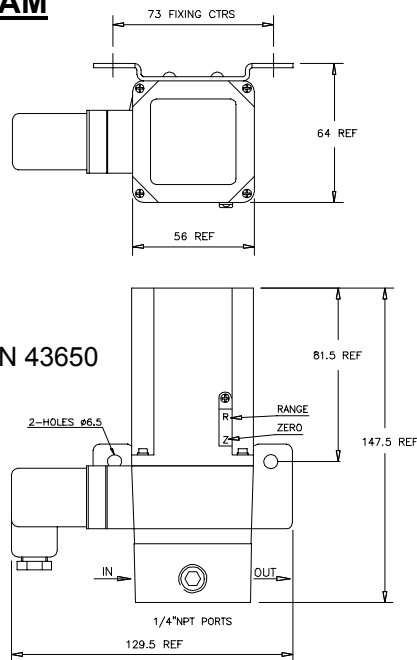

Pneumatic connections:
1/4" NPT or 1/4" BSP Female

Electrical connections:
30mm square connector DIN 43650
(provided)

CHARACTERISTIC GRAPHS

Model 422 Forward Flow Capacity at 12mA, 1.3, 2 and 4 bar Supply Pressure

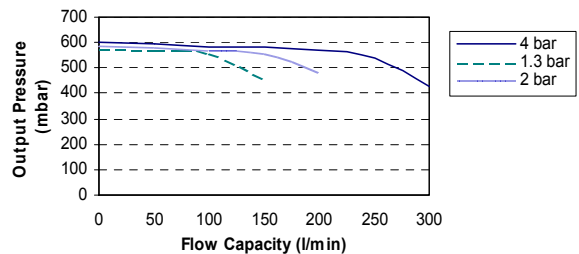

ORDERING INFORMATION & ACCESSORIES

Standard Models: 4-20mA input, forward action, DIN connector

OUTPUT PRESSURE	ORDER CODE
0.2-1bar	AC2100
0.2-8bar	AC2400
3-15psi	AC0100
3-120psi	AC0400

Options to special order:

- Alternative pressure ranges
- Conduit entry (M20 / 1/2" NPT)
- 50mm pipe mounting bracket
- Intrinsically safe certification
- Type 'nL' certification
- Reverse Acting
- Captured Bleed

CERTIFICATION

Hazardous area approvals:

The 422 is available for: Intrinsically safe applications to EN50020:2002 with II 1G EEx ia IIC T4 (Ta= -40°C to +80°C)
Type nL applications to EN50021:1999 with II 3G EEx nL IIC T6 (Ta= -40°C to +70°C)

Norgren Ltd.,
Cross Chancellor Street,
Leeds, LS6 2RT. England.
Telephone: +44 (0) 113 245 7587
Fax: +44 (0) 113 246 5735
Email: salesenquiries@norgren.com

Our Ref: ds422N 05/06
Controlled Doc. 2006-117a

All instruments are tested on the Watson Smith Automatic Testing System and an individual test certificate is provided at no extra charge. Each unit is tested for linearity, hysteresis, total error, air consumption, response time and supply sensitivity.

Our policy is one of continuous research and development. We therefore reserve the right to amend without notice the specifications given in this document. Customers are responsible for ensuring that the product is used only for the purpose for which it is intended. In case of doubt Norgren will be pleased to advise.